



PROCESS CONTROL ACADEMY 2005



A showcase of the latest techniques and application stories for the very best in industrial process control

**27 - 29 September
2005
Leicester, UK**

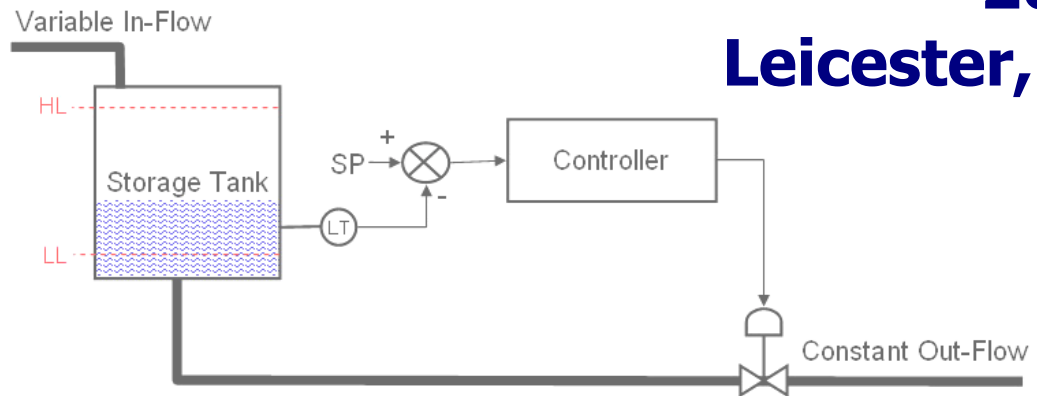

Highlights:

- 3 days of lectures by industrial experts and leading academics
- structured programme to allow you to attend whichever days you want
- control methods with proven industrial applications
- comprehensive course notes provided

Register now:

www.isc-ltd.com/processacademy

PROCESS CONTROL ACADEMY 2005

27 – 29th September 2005

Leicester, UK

INTRODUCTION....

This new training and awareness event from organised by the ACTC and supported by Emerson Process Management, will provide a valuable and unique overview of enhanced control and plant monitoring techniques through end-user application stories and overviews of the latest software tools. The focus is on techniques that provide a competitive advantage through greater reliability, robustness and performance.

TARGET AUDIENCE....

- Process Control Engineers wishing to refresh their knowledge and understand the latest techniques.
- Managers requiring an up-to-date overview of quality improving technology.
- Operations and Production Staff looking for ways to get more from their plant.

CHOOSE ONE, TWO OR ALL THREE OF THE DAYS LISTED BELOW!

YOU CAN ATTEND WHICHEVER DAYS YOU WISH. THE COST IS £250 FOR DAY 1 AND £175 FOR EACH OF DAY 2 OR DAY 3. COME TO ALL THREE DAYS FOR £500.

ACTC MEMBER COMPANIES ARE ENTITLED TO TWO FREE PLACES, WITH ADDITIONAL PLACES AT HALF PRICE. DISCOUNTS ALSO AVAILABLE FOR IEE/INSTMC/ICHEM MEMBERS AND GROUPS – SEE THE REGISTRATION FORM

DAY 1

"GETTING THE BASICS RIGHT"

This is the ACTC's highly regarded "Introduction to Process Control" training course, providing a suitable introduction for those new to process control or a refresher for old-hands attending Days 2 and 3. Covered are the basics of process dynamics; control and loop tuning; how to identify and alleviate common problems; enhanced control such as feed-forward and cascade control. The learning is reinforced using real-life examples.

DAY 2

"TURNING ADVANCED CONTROL INTO APPLIED CONTROL"

This day will see the introduction and application of model predictive control, the most widely employed advanced strategy for difficult to control processes. Whilst MPC is still largely confined to oil refineries, new tools are allowing this technology to extend to other processes. The additional complexity of nonlinearities, such as pH, is covered together with proven and new control strategies to overcome them. The final part of the day looks at new tools for extracting valuable information from the mass of data that today's control systems produce.

DAY 3

"REALISING IMPROVEMENTS TO YOUR PROCESS"

The final day addresses issues about how to make control work and how to keep it working. The day begins with the automatic assessment of the performance and condition of your control loops, without even leaving your desk!! The afternoon looks at the broad topic of justifying and carrying out improvements to your control system, including system life planning, the use of modelling, and the opportunities offered by new control systems hardware and infrastructures.



TIMETABLE

DAY 1	DAY 2	DAY 3
9.00am – 9.30am Basics of Process Control	9.00am – 9.45am Guest Speaker	9.00am – 9.45am Guest Speaker
9.30am – 10.30am The Process and Dynamics	9.45am – 10.40am Model Predictive Control	9.45am – 10.45am How are your Control Systems Performing?
10.30am – 10.50am Tea / Coffee	10.40am – 11.00am Tea / Coffee	10.30am – 10.50am Tea / Coffee
10.50am – 12.45pm Applying Control to the Processes	11.00am – 12.20pm Model Predictive Control (Cont.)	10.50am – 12.20pm How are your Control Systems Performing? (Cont.)
12.45pm – 1.45pm Lunch	12.20pm – 1.30pm Lunch	12.20pm – 1.30pm Lunch
1.45pm – 2.40pm Real-Life Process Control Problems	1.30pm – 3.00pm Unlocking Value in Your Data	1.30pm – 3.00pm How to Make Improvements Happen
2.40pm – 3.00pm Tea / Coffee	3.00pm – 3.20pm Tea / Coffee	3.00 – 3.20pm Tea / Coffee
3.00pm – 4.30pm Enhanced Process Control	3.20pm – 4.40pm Coping with nonlinear Processes	3.20pm – 4.30pm How to Make Improvements Happen (Cont.)
4.30pm – 5.00pm Questions and Close	4.40pm – 5.00pm Questions and Close	4.30pm – 5.00pm Questions and Close
	7.00pm Evening Process Academy Dinner	

THE APPLIED CONTROL TECHNOLOGY CONSORTIUM

The Applied Control Technology Consortium (ACTC) helps companies pursue a policy of understanding and appropriately applying control technologies. The ACTC has been self-financing since 1993 and has grown to become truly international. It now provides control technology support to 35 'world-class' companies operating in industries as diverse as Automotive, Aerospace & Defence, Chemical & Petrochemical, Energy, Marine, Metal Processing, Food and Drink manufacturing.

The success in meeting the expectations and needs of its member companies can be attributed to the Consortium's flexibility and responsiveness in sharing an understanding of industrially relevant technology. A Steering Committee, made up of representatives from member companies, ensures that the ACTC serves the needs of its members.

EMERSON PROCESS MANAGEMENT

Emerson Process Management is a leading supplier of process management solutions that help automate, control and manage complex plant processes used in the chemical pulp and paper, power, food and beverage, refining, oil and gas, pharmaceutical, and other industries. The company combines superior products and technology solutions with industry-specific engineering, consulting, project management, and maintenance services.

VENUE

This event is being hosted by Emerson Process Management at their UK Headquarters in Leicester (Meridian East Business Park, LE19 1UX Tel: 0116 282 2822). The venue provides convenient access by road (M1 Junction 21, M69) and air (East Midlands Airport). For more details, including maps and hotels please see our website.

FOR MORE INFORMATION

Contact Lesley Breen:

Tel: +44 (0) 141 553 1111

Fax: +44 (0) 141 553 1232

Email: actc@isc-ltd.com

or visit our website:-

www.isc-ltd.com/processacademy

PROCESS CONTROL ACADEMY 2005

27 – 29th September 2005

Leicester, UK

REGISTRATION FORM

To register for the course please complete in BLOCK CAPITALS and send with proof of payment to the address given below.

Surname (incl. title) : First name(s) :

Company/Organisation :

Job Title :

Address :

.....

Tel. : Fax :

Email :

Current Area of work :

Special Requirements (e.g. vegetarian) :

I would like to attend:-

Day 1 – Getting the Basics Right £250

Day 2 – Turning Advanced Control into Applied Control £175

Day 3 – Realising Improvements to your Process £175

Days 1- 3 £500

Process Academy Dinner - Day 2 evening (incl. with registration) £Incl

Discounts

ACTC Member Company – first two places are free, additional places at half price. (No further discounts apply)

IEE / InstMC / IChemE Member – 10% off for each member

Membership No:

Two delegates from same company – 10% off total price. Contact us for discounts for bigger groups

Please reserve place(s) on the course.

Additional Names:

Total Sum payable £..... please refer to the terms and conditions below

Company VAT ID No. (only needed if from a non-UK European Community country)

Please indicate method of payment:

Cheque enclosed payable to Industrial Systems and Control Limited.

Payment sent by PayPal. (www.paypal.com/uk make payment to iscmal@isc-ltd.com)

Bank transfer to: Industrial Systems and Control Ltd. (**Please include the delegate's names on the transfer**)

The Royal Bank of Scotland plc, Gordon St, Glasgow, G1 3PL, Scotland Sterling Acc No: 00644350, Sort Code: 830706.

Purchase order: Please invoice my company/organisation at the address below.

Order Number :

Name (if different to above) :

Address :

Tel : Fax :

Alternatively, you may register on-line at www.isc-ltd.com/processacademy

IMPORTANT - Fees are payable in advance and must be received two weeks prior to the commencement of the course/event. Full payment, or proof of payment, must accompany all registrations. Your registration is not confirmed until payment is received. Cancellation: Fees will be refunded, less 10% handling charge, for any cancellation received in writing 14 days prior to the course. For cancellations after this date and no shows, we reserve the right to charge the full rate. Substitute delegates are welcome at any time. We also reserve the right to modify or cancel training courses, giving adequate notice and refunds to registrants. VAT (Value Added Tax): Companies within the UK pay the amount excluding VAT. Companies from other European Community countries pay the amount excluding VAT only when the company VAT ID No has been provided. If this is not provided then the amount including VAT will be charged at the current UK rate of 17.5%. Companies from outside the European Community pay the amount excluding VAT.